

# Prodigy™ Flaked and Nugget Ice Machines

**Scotsman®**

## Technical Review

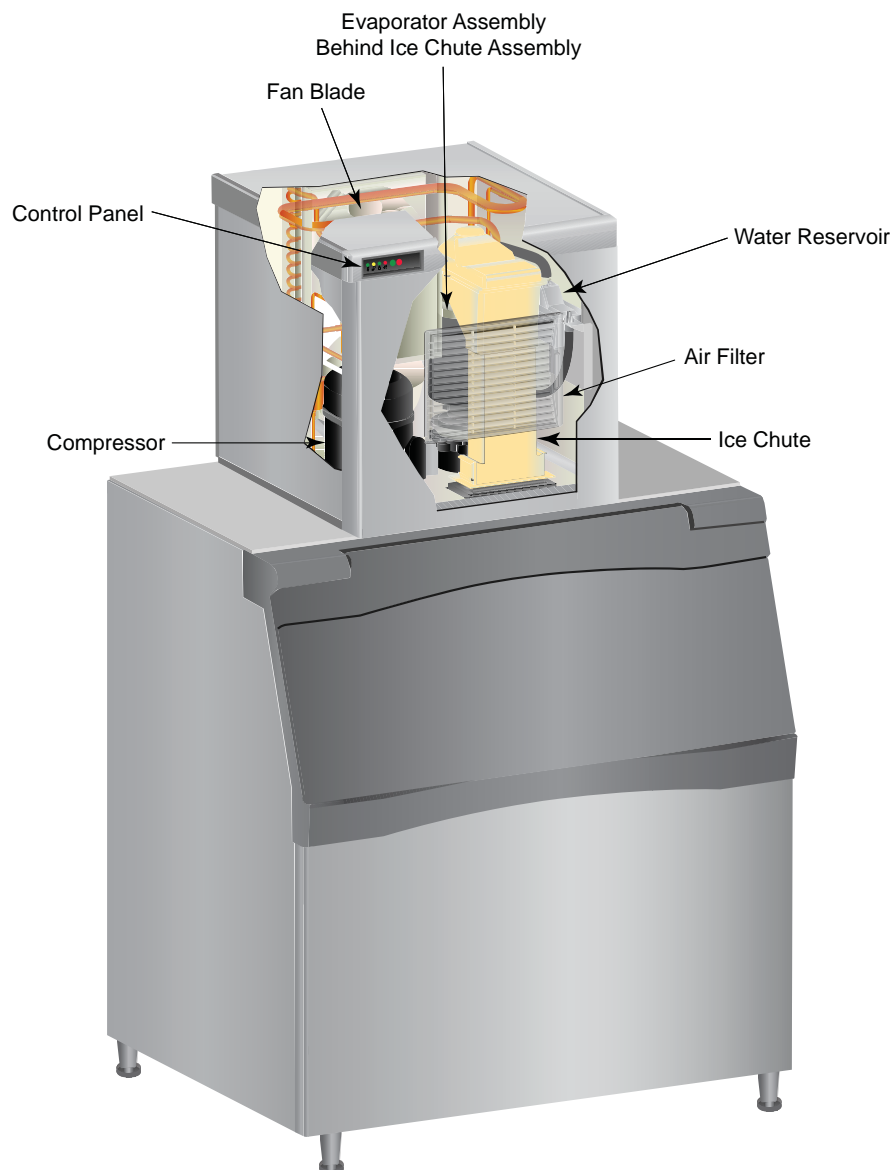

# Prodigy Flaked and Nugget Ice Machines

## Refrigeration and Water Systems

The refrigeration system consists of a hermetic compressor, condenser, thermostatic expansion valve and evaporator. The condenser could be air cooled, water cooled or remote air cooled. The evaporator is a refrigerated stainless steel tube, mounted vertically with a slowly rotating auger inside.

The water system consists of a water reservoir with a float valve. The water flows from the water reservoir to the evaporator inlet. As ice is made replacement water flows out of the reservoir and into the evaporator. The float valve maintains the water level in the reservoir, which is the same level that is in the evaporator freezing tube.

Refrigeration effect changes water in the tube to crystalline ice, which is continually forced up the tube by the auger. At the top of the evaporator tube, the ice crystals are pushed through small holes, changing the ice to a usable form by squeezing out much of the water content and compressing it into either flaked or nugget ice, depending upon the model type.

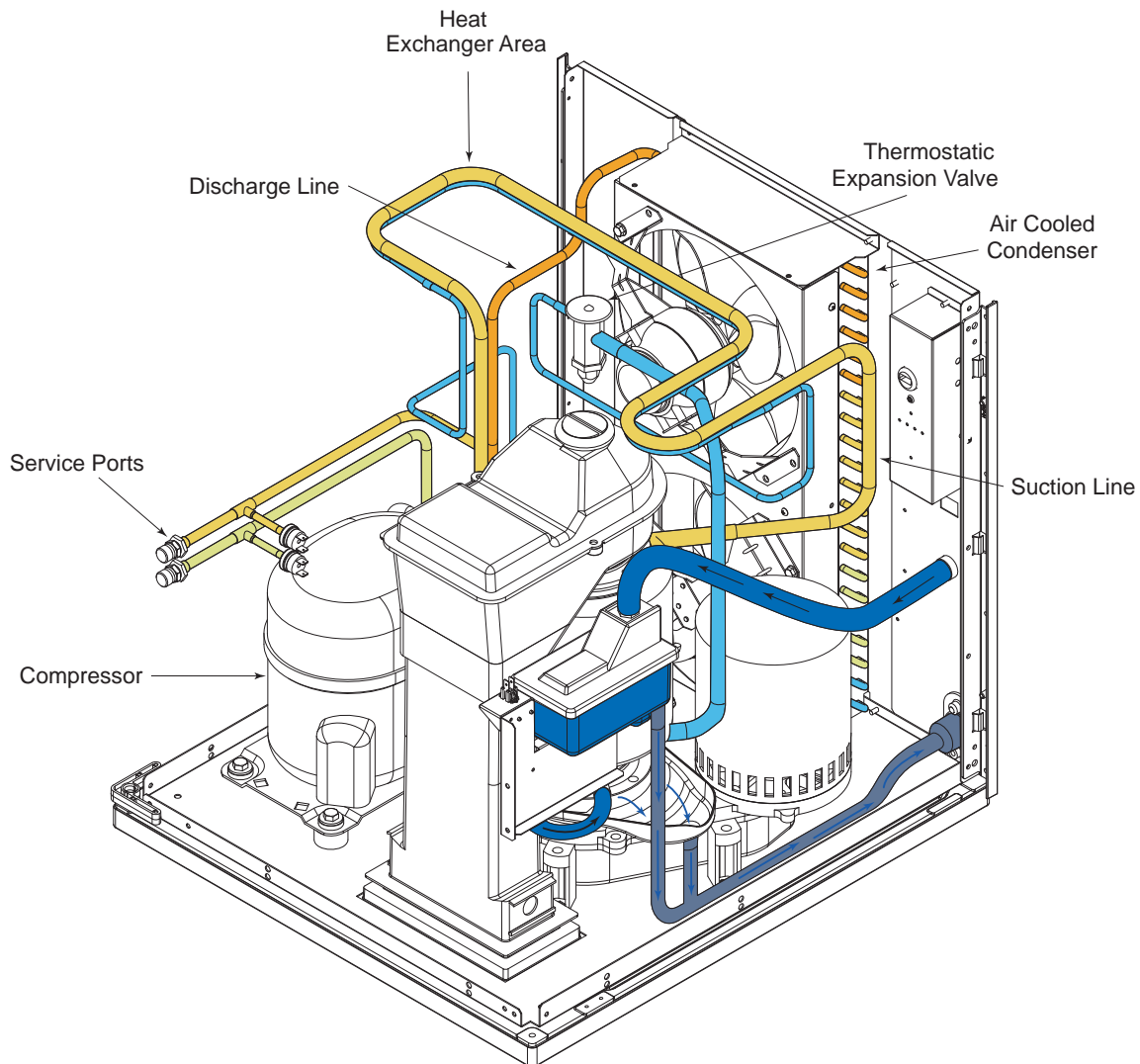

# Prodigy Flaked and Nugget Ice Machines

## Control System

The control system consists of a central controller, an ice sensor, a water sensor, and a high pressure cut out switch.

The ice sensor is a set of photo-electric eyes mounted in the base of the ice chute. The water sensor is a conductivity probe, connected to the water supply by a tube from the reservoir. The high pressure switch is a refrigerant pressure control. The high pressure cut out, which shuts the compressor off if the discharge pressure gets too high, will automatically reset when the discharge pressure falls below its set point.

The controller operates from a 12 volt power supply, and uses inputs from the sensors to switch relays on and off. The relays operate the motors and, on some models, solenoids. All solenoids are line voltage.

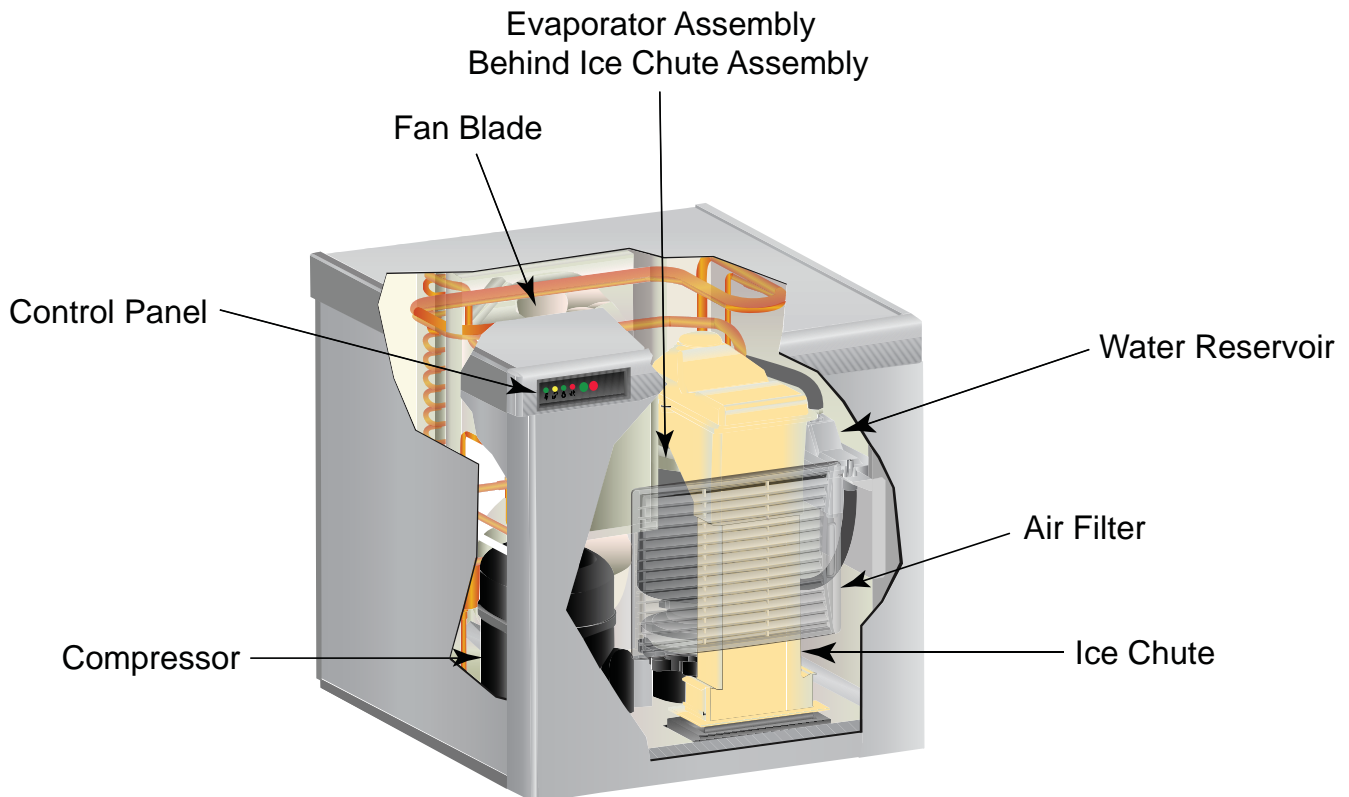

# Prodigy Flaked and Nugget Ice Machines

## Initial Start Up or Restart

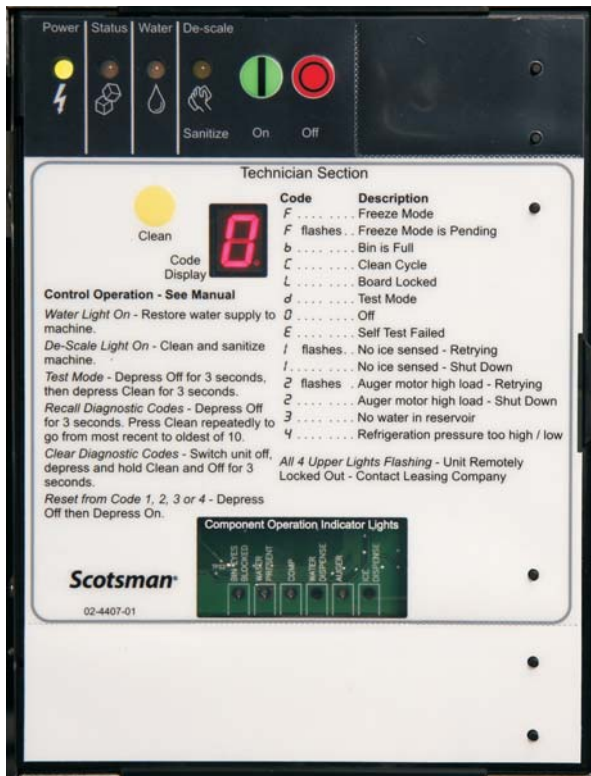

When power is supplied, the four lights at the top and the display indicator will blink on and off one time. Then the Power light will be on and a 8 is displayed.

When the Power light is ON and the Status light is OFF, the controller is in the Standby mode.

Push and release the On button to start the ice making process.

The Status light will then switch On; it and the Power light will normally both be On during machine operation.

## Ice Making Mode & Auger Motor Monitor

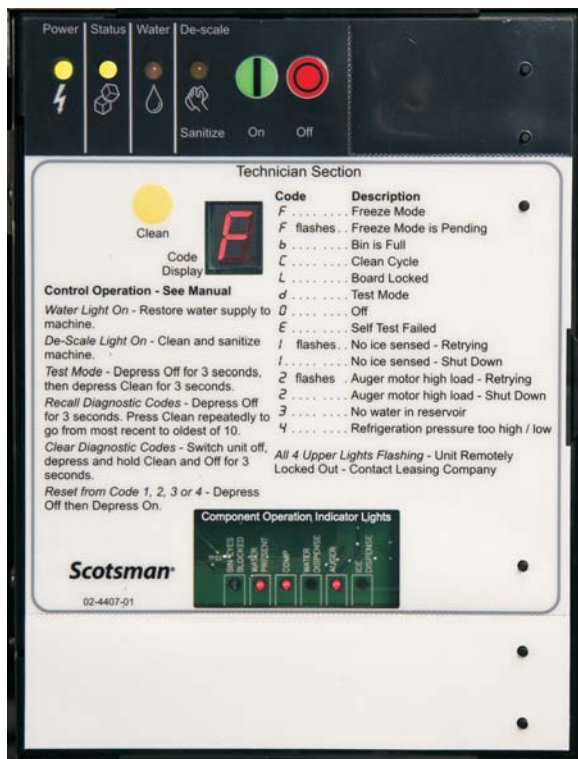

At the beginning of any restart the controller will display a blinking F.

Once the compressor has started, the F will be displayed continuously. When the bin is full, and the machine shuts off, a b will be displayed.

The power required to operate the auger motor is monitored during ice making. If the power used exceeds a pre-set limit, the controller will shut the compressor and auger motor off. A blinking 2 will show on the code display. After a pre-determined time, the ice making process will restart. If the auger motor power exceeds the limit three consecutive times, the machine will shut down and must be manually reset. A continuous 2 will be displayed.

# Prodigy Flaked and Nugget Ice Machines

## Indicator Lights



There are four indicator lights: Power, Status, Water and De-scale / Sanitize.

The power light will be on anytime the controller has power.

The Status light will be on anytime the machine has been switched on to ice making. When used with a Smart-Board, a blinking status light indicates that the machine may need attention.

The Water light will only be on if there is a lack of water.

The De-scale / Sanitize light will switch on after the time period set for notification has expired.

## Scale Removal and Sanitization

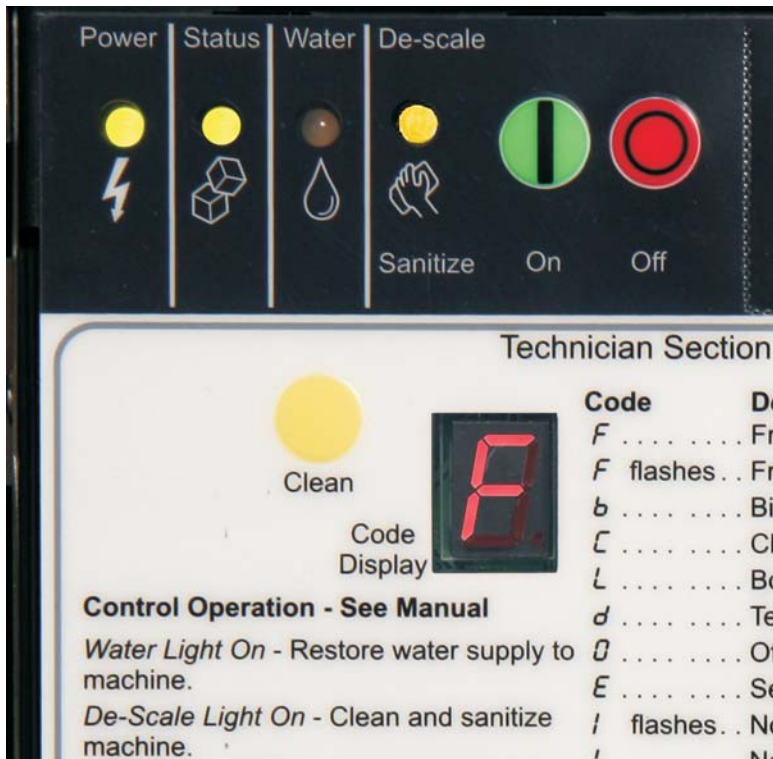

After 6 months of power up time, the De-Scale & Sanitize light will be switched On. It will switch off after the machine has been through a cleaning process, as described here:

After shutting off the water and draining the reservoir, fill the reservoir with a scale remover solution. Then push and release the Clean button to start the Clean cycle. The auger motor will operate for 20 minutes, then the compressor will start. Keep adding scale remover solution until it is all gone, then reconnect the water supply. After 20 minutes of ice making, the process is complete and the unit shuts off.

Push and release the Off button to end the process.

# Prodigy Flaked and Nugget Ice Machines

## Change Cleaning Notification Interval

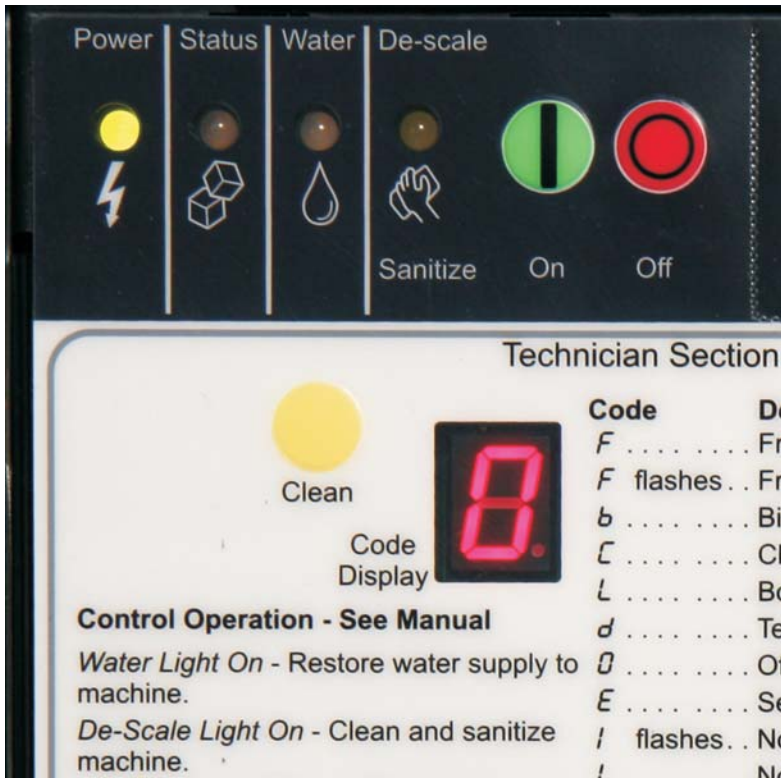

This feature is accessible only from standby (Status Light Off).

Press and hold the Clean button for 3 seconds to switch the control to the time to clean adjustment state. The code display will show the current time to clean in months or years.

Pressing Clean button repeatedly will cycle through one of 4 possible settings:

- 4 months
- 6 months (default)
- 1 year
- 0 or never

Push Off to select the setting shown in the display.

## Recall Diagnostic Codes

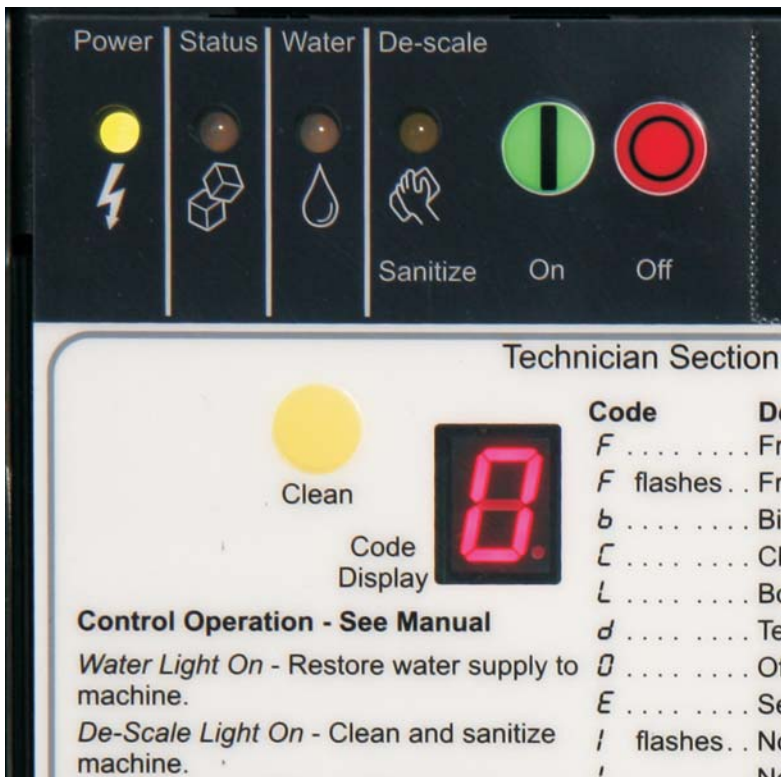

From the standby state, press and hold off button in for 3 seconds, then release it.

Press and release the Clean button to cycle through each of the last 10 error codes from most recent to oldest.

The list of code meanings is on the label next to the display.

To clear all diagnostic codes, press and hold the Clean and Off buttons in for 3 seconds.

# Prodigy Flaked and Nugget Ice Machines

## Test Cycle

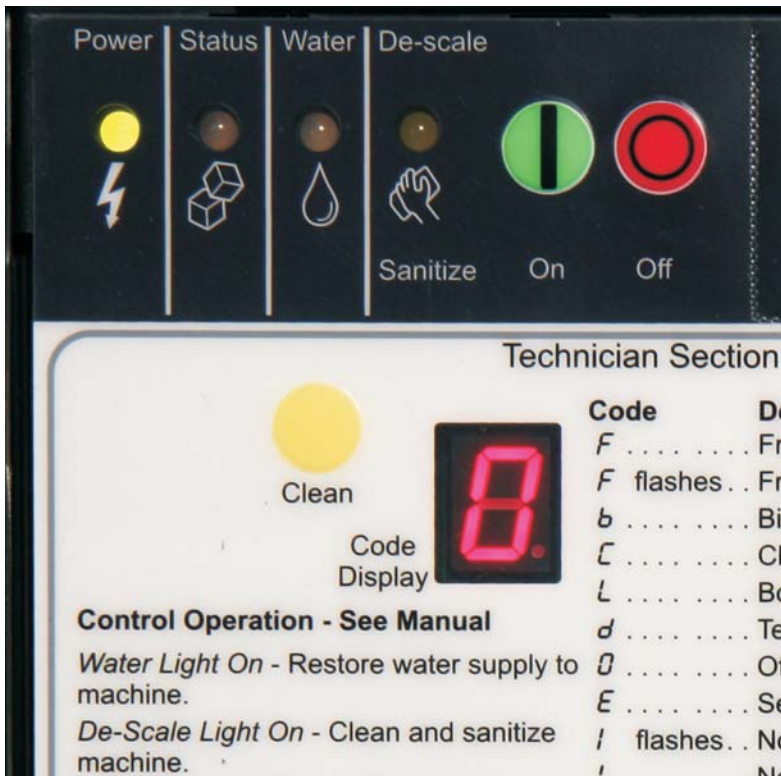

The control can be put into a Test Cycle, where it switches all the loads on and off in a logical sequence. This allows the technician to confirm controller operation of all parts.

To start the test cycle, from the standby state, depress Off for 3 seconds then release it. Then depress Clean for 3 seconds.

The Status light will blink green, and the display will show *d*.

The test cycle will begin and end automatically.

## Ice Detection

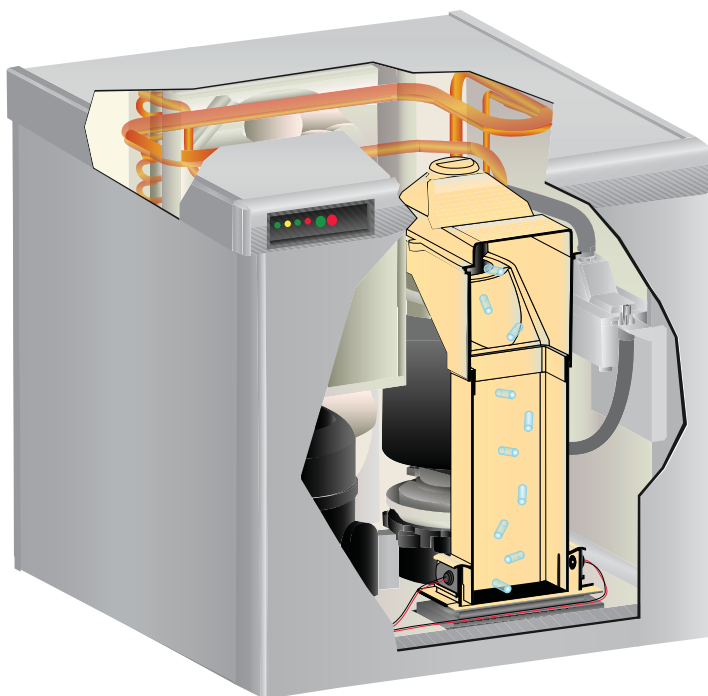

The control system checks for operation by using the photo-electric eyes to detect ice as it is made.

The first 6 minutes of operation are ignored to give the machine time to start making ice.

If no ice is sensed within a set period of time, the control will shut the machine down for 10 minutes and the incident will be added to a strike counter.

The cycle will repeat and if no ice is sensed three times in a row, the machine will shut down on no ice error and must be manually reset.

## Diagnostic Codes

Code	Description
F - - - - -	Freeze or ice making mode
F flashes - - - -	Ice making is pending
b - - - - -	Bin is full
C - - - - -	Clean cycle
L flashes* - - -	Board remotely locked out
L - - - - -	Board locked by button press
d - - - - -	Test mode
0 - - - - -	Off
E - - - - -	Self test failed
I flashes - - - -	No ice sensed, restart mode
I - - - - -	No ice sensed, requires manual reset
2 flashes - - - -	Auger motor over amp, restart mode
2 - - - - -	Auger motor over amp, requires manual reset
3 - - - - -	Slow water fill
4 - - - - -	Pressure control open

*\* and all 4 Upper Lights Flashing*

---

### Scotsman Ice Systems

775 Corporate Woods Parkway, Vernon Hills Ill. 60061.  
800-SCOTSMAN. [www.scotsman-ice.com](http://www.scotsman-ice.com)